

seko

Blowers

Side channel compressors and vacuum pumps



Your Choice,
Our Commitment

SEKO's range of side channel blowers are an effective solution to for air displacement in many applications.

Side Channel blowers are the first choice in many automation projects for applications requiring large volumes of clean, dry air at low pressures and vacuums. SEKO has sought to deliver a product that offers easy installation as with our other products but also offers low operating noise levels in a small light weight design with operational energy saving in mind.

Side channel compressors and vacuum pumps

Side channel blowers work according to an impulse principle, or regenerative flow. This means that kinetic energy from a rotating impeller is transferred to the pumping medium and converted into pressure. The impeller is mounted directly on the motor shaft for frictionless compression and, together with the specially shaped housing, forms the side channel. The pumping medium is sucked in, compressed in the side channel and conveyed to the second stage after one rotation.

Here, it is compressed again before being discharged. This way a side channel blower can be used to generate both vacuum and blast air. The motor rated power determines the maximum differential pressure of the blower. Silencers fitted to the inlet and discharge sides ensure quiet operation while maximum operational reliability, even at high differentials, is ensured by having the bearings outside the compression chamber.



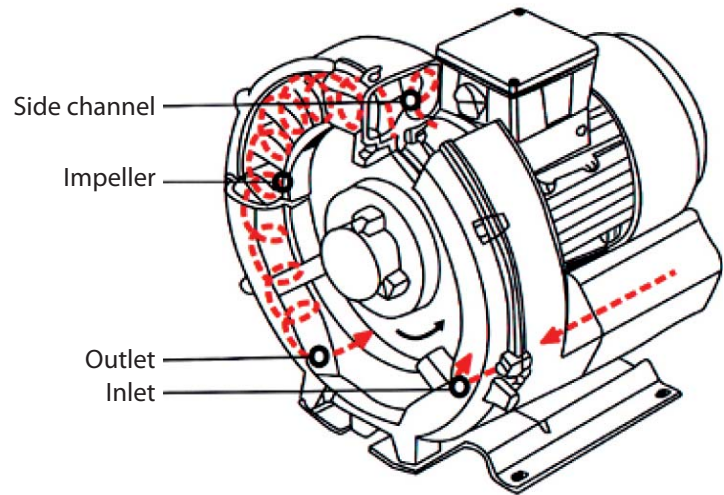

Performance advantages

New variable frequency drive allows **maximum performance** of a common motor driven unit to be **improved by 300%**. The precision machine tool cutting, ensures the **accuracy and quality**, of the blower. All products go through a **strict mechanical and electrical performance test**, using PROE, UG, CAD and other computer aided design software and motion simulations that test all the design features prior to final manufacture.

Dual frequency (50/60HZ) and wide voltage can meet almost **all the voltage levels in all regions of the world**, while the external design of the bearing, can bear high working temperature, and improves the **reliability and service life of the blower**.

Aluminium alloy one-time die-casting molding, machining parts completed in the cutting process, ensure **accuracy improvement** of traditional technology. The impeller design **increases performance versus competitor products of 20%** while its IP55 class protection (class F insulation) makes it suitable for applications worldwide.

Operating principle

The impellers are mounted directly on the motor shaft for noncontact compression entirely without friction. Maximum operational reliability, even at high differential is ensured by the arrangement of the bearings outside the compression chamber.

The gas is taken in through the **Inlet**. As it enters the **Side Channel**, the rotating **Impeller** imparts velocity to the gas in the direction of rotation. Centrifugal force in the impeller blades accelerates the gas outward and the pressure increases. Every rotation adds kinetic energy.

Resulting in the further increase of the pressure along the side channel. The side channel narrows at the rotor, sweeping the gas off the impeller blades and discharging it through the **Outlet** silencer where it exits the side channel blower.

The unique principle of operation and design brings key advantages of

No wearing parts

No lubrication required

Minimum maintenance

Silent operation

Smooth air flow

Can be mounted in any direction, with reduced footprint and installation costs



Product line

SINGLE IMPELLER

Flow rate	from 40 to 1370 m ³ /h
Pressure	from 70 to 480 mbar
Vacuum	from -60 to -340 mbar
Motor	Single or 3-Phase
Noise	from 46 to 71 dB A



DOUBLE IMPELLER

Flow rate	from 47 to 2050 m ³ /h
Pressure	from 240 to 820 mbar
Vacuum	from -200 to -500 mbar
Motor	Single or 3-Phase
Noise	from 58 to 84 dB A



TRIPLE IMPELLER

Flow rate	170 m ³ /h
Pressure	1050 mbar
Vacuum	-730 mbar
Motor	3-Phase
Noise	72 dB A



Fine bubble membrane air diffusers

Membrane air diffusers: rubber surface with microholes that act like one valve, dilating themselves in order to let out the air but closing up once the flow is interrupted preventing the water to enter.

Activated sludge process is the main stage of modern wastewater treatment technology. Aeration systems which are key component of the activated sludge process serve two purposes; satisfy oxygen demand and provide sufficient mixing turbulence to keep solids in suspension.

Oxygen must be provided in biological activated sludge wastewater treatment systems to satisfy several types of demands:

Organic oxygen demand that can be further divided into oxygen required for cell synthesis and oxygen required for endogenous respiration;

Biological oxidation of ammonia nitrogen;

Oxidation of certain inorganic materials that may be present in the wastewater.



9" - 12" DISC DIFFUSER

Material EPDM; Silicone

Outlet NPT 3/4" - 1" male

Effective-Total Length

9" 270-300 mm ; 12" 340-370 mm

Effective Area

9" 0,04 m² ; 12" 0,07 m²

Capacity

9" 2-10 m³/h ; 12" 2-12 m³/h

STRONG BODY REINFORCED GLASS FIBER

Material EPDM; Silicone

Thickness 2 mm

Density 1.06/1.13 ± 0,05

Tensile Strength >10 N/mm²

Hardness 50 ± 5 ShoreA

Temperature -45 – 150/310 °C

Tubular diffusers

Tubular diffusers: rubber surface with microholes that act like one valve, dilating themselves in order to let out the air but closing up once the flow is interrupted preventing to the water to enter.

Tube Diffuser

Material EPDM; Silicone

Outlet NPT 3/4" - 1" male

Effective-Total Length

300-350 mm ; 500-550 mm ;

800-850 mm ; 1000-1050 mm

Effective Area

0,06 m² ; 0,10 m² ; 0,15 m² ; 0,20 m²

Capacity

2-5 m³/h ; 2-8 m³/h ; 2-10 m³/h ; 2-15 m³/h



Accessories

A complete range of accessories is available for all machines: cartridge type filters for blowers / in-line filters for exhausters / flexible hoses / non return valves / pressure relief valves for blowers / vacuum relief valves for exhausters / pressure and vacuum gauges / acoustic enclosures.



Applications

- Wastewaters treatment
- Clean water treatment
- Industrial Processes
- Swimming Pools
- Sludge stabilization
- Aeration of fish pond
- Aeration of streams and lakes
- Pneumatic Transport
- Drying, Suction, and Plastic

Your Choice, Our Commitment

In the modern Globalised world, being a privately owned Company has significant benefits especially for our Customers, our Partners. For over 40 years, SEKO has developed a Global organisation able to take the longer view, manage the pressure of the now, and to plan for the long term, delivering true Partnership for our Customers, with transparency and mutual respect for each other.

Whether it's for our reknown flexibility, our attention to detail, the high-quality products, or just the way we do business, we understand that it's Your Choice to do business with us. It is Our Commitment to fulfill your needs wherever you, our Customers are.



For more information about our portfolio, worldwide locations, approvals, certifications, and local representatives, please visit www.seko.com

As part of a process of on-going product development, SEKO reserves the right to amend and change specifications without prior notice. Published data may be subject to change.

© SEKO, Layout and origin: Italy, 850001-Blower_en, 08.2017

The SEKO logo is positioned at the bottom right of the page. It features the word "seko" in a bold, lowercase, blue sans-serif font. The background of the entire page is a light blue gradient with a dynamic splash of water and bubbles on the right side.